



 Rotatori idraulici
 Hydraulic rotators
 Rotators hydrauliques

 Hydraulische Drehmotoren
 Rotores hidráulicos
 Гидравлические ротаторы

> R102



> R103A





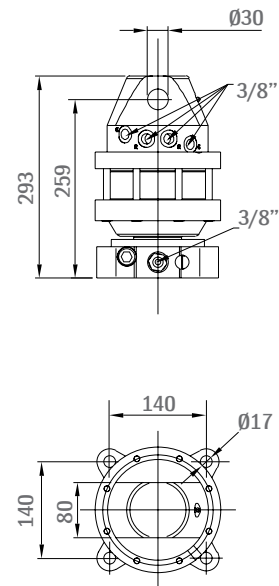
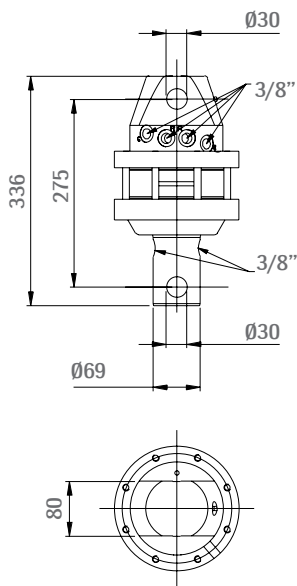
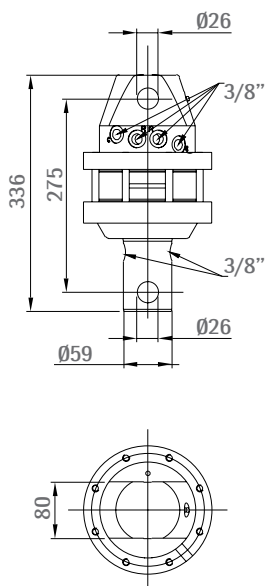

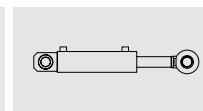
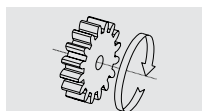
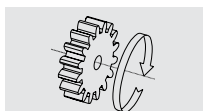

> R103F



Modello	Portata	Peso	Coppia	Pressione	Portata olio	Pressione
Model	Lifting capacity	Weight	Torque	Pressure	Oil flow	Pressure
Modèle	Portée	Poids	Couple	Pression	Débit d'huile	Pression
Modell	Tragkraft	Gewicht	Drehmoment	Druck	Ölleistung	Druck
	t	kg	kgm	bar	l/min	bar
R102	2	25	100	250	20	300
R103A	2,5	28	110	250	20	300
R103F	2,5	35	110	250	20	300



-  Rotatori idraulici
-  Hydraulic rotators
-  Rotators hydrauliques

-  Hydraulische Drehmotoren
-  Rotores hidráulicos
-  Гидравлические ротаторы

> R104A

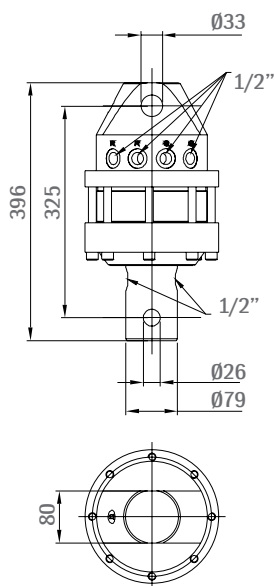

> R104F

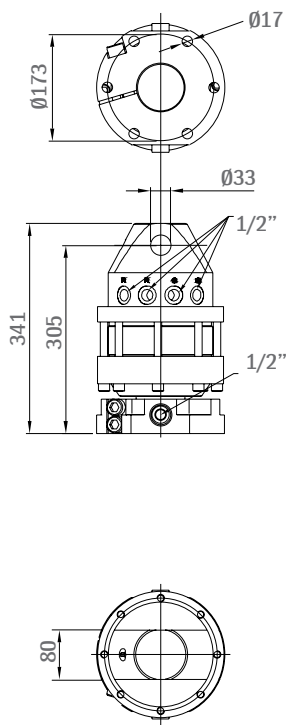

> R05

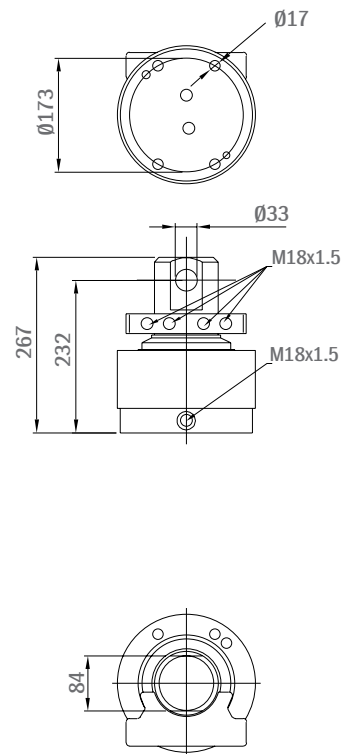

Modello	Portata	Peso	Coppia	Pressione	Portata olio	Pressione
Model	Lifting capacity	Weight	Torque	Pressure	Oil flow	Pressure
Modèle	Portée	Poids	Couple	Pression	Débit d'huile	Pression
Modell	Tragkraft	Gewicht	Drehmoment	Druck	Ölleistung	Druck
	t	kg	kgm	bar	l/min	bar
R104A	3	40	140	250	25	300
R104F	3	46	140	250	25	300
R05	3	31	104	200	20	300

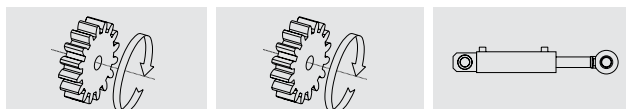



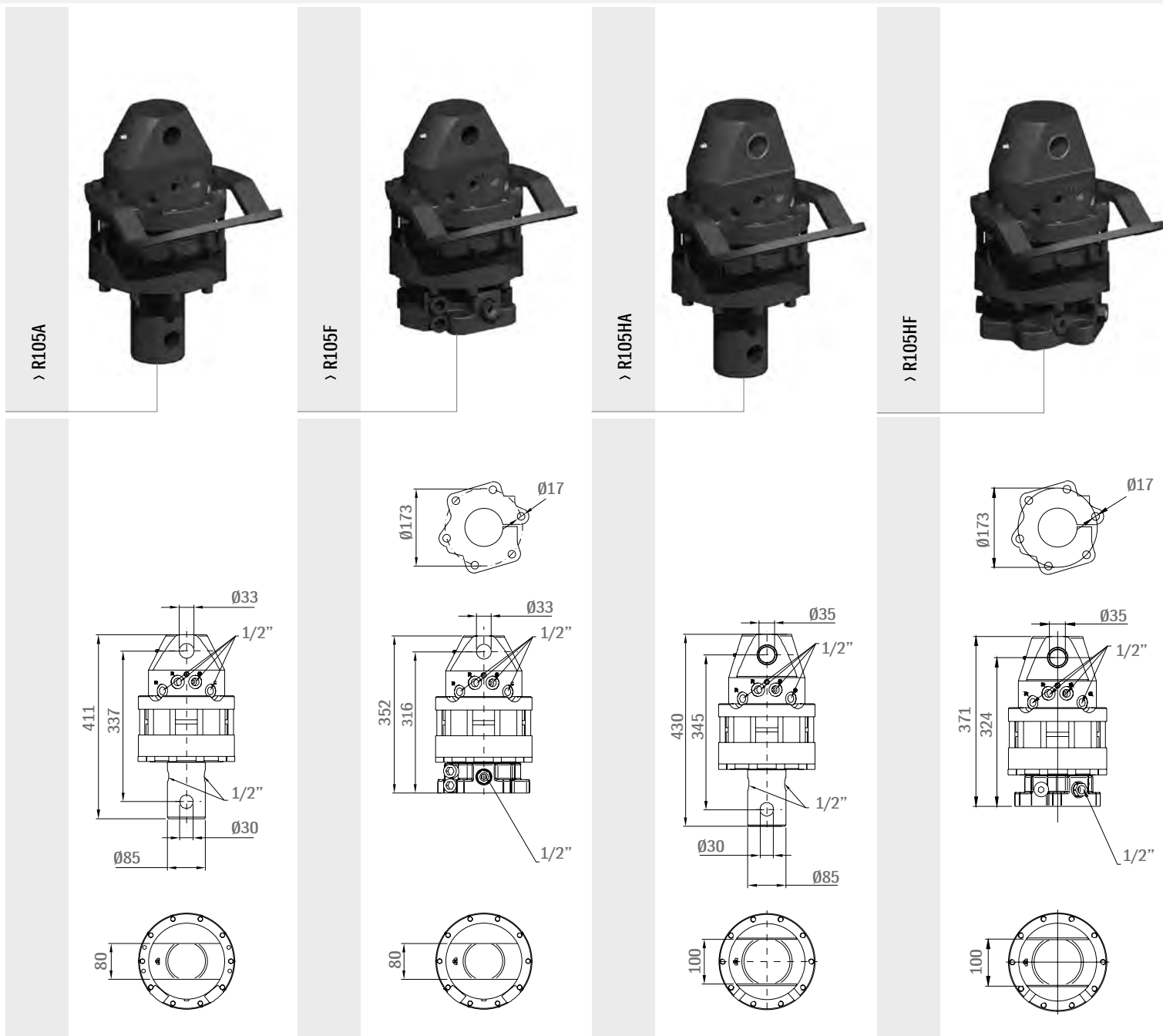

- Rotatori idraulici
- Hydraulic rotators
- Rotators hydrauliques

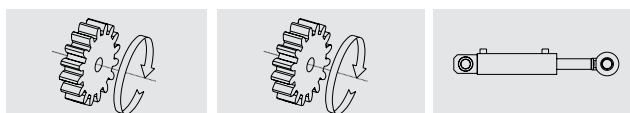

- Hydraulische Drehmotoren
- Rotores hidráulicos
- Гидравлические ротаторы



Modello	Portata	Peso	Coppia	Pressione	Portata olio	Pressione
Model	Lifting capacity	Weight	Torque	Pressure	Oil flow	Pressure
Modèle	Portée	Poids	Couple	Pression	Débit d'huile	Pression
Modell	Tragkraft	Gewicht	Drehmoment	Druck	Ölleistung	Druck
	t	kg	kgm	bar	l/min	bar
R105A	4	53	180	250	25	300
R105F	4	60	180	250	25	300
R105HA	4,5	55	180	250	25	300
R105HF	4,5	62	180	250	25	300



-  Rotatori idraulici
-  Hydraulic rotators
-  Rotators hydrauliques

-  Hydraulische Drehmotoren
-  Rotores hidráulicos
-  Гидравлические ротаторы

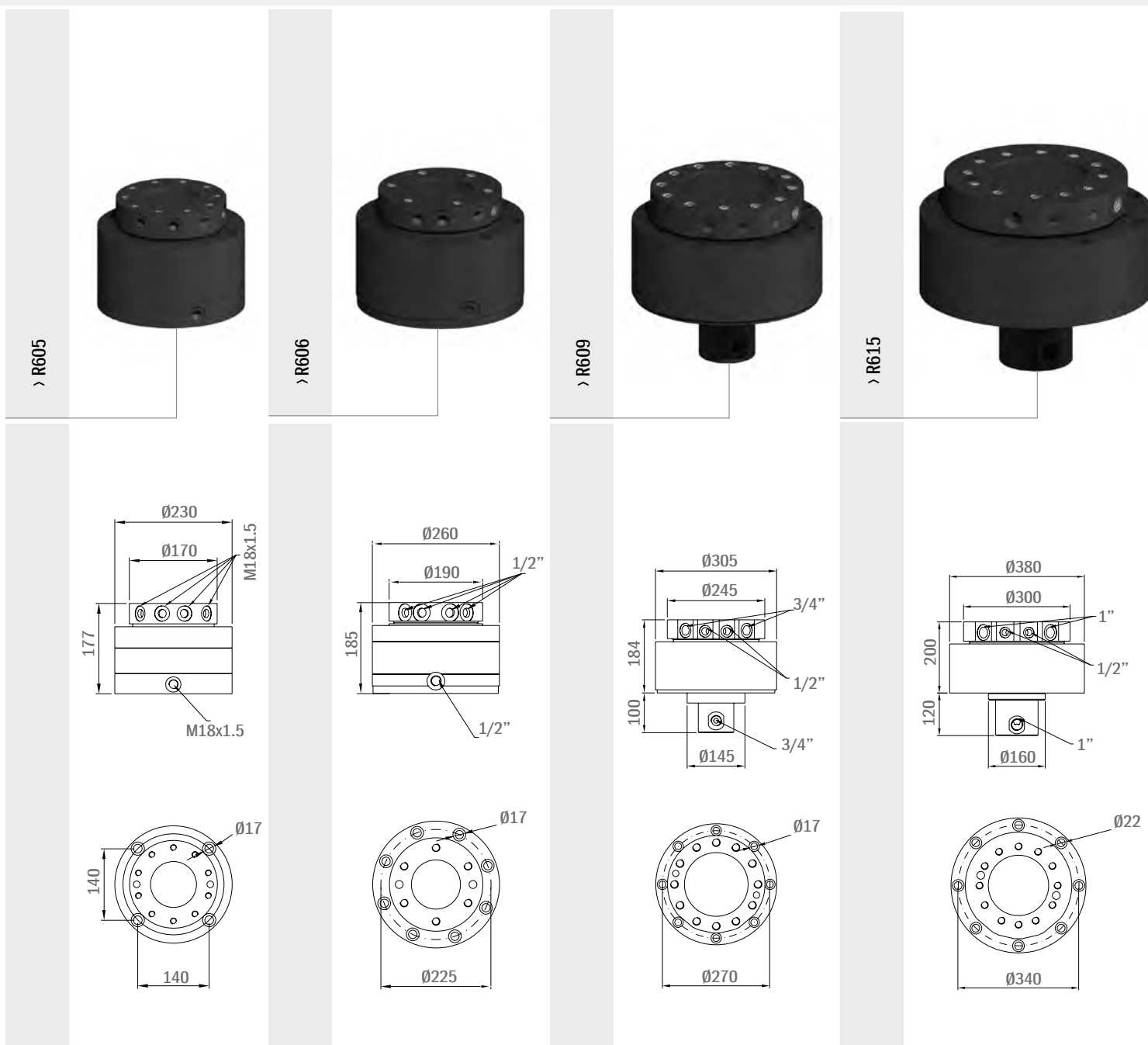

Modello	Portata	Peso	Coppia	Pressione	Portata olio	Pressione
Model	Lifting capacity	Weight	Torque	Pressure	Oil flow	Pressure
Modèle	Portée	Poids	Couple	Pression	Débit d'huile	Pression
Modell	Tragkraft	Gewicht	Drehmoment	Druck	Ölleistung	Druck
	t	kg	kgm	bar	l/min	bar
R605	5	40	125	250	15	350
R606	6	55	165	250	20	350
R609	9	75	300	250	25	350
R615	15	137	550	250	35	350

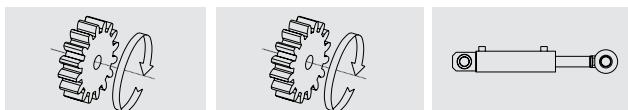

- ■ Rotatori idraulici
- ■ Hydraulic rotators
- ■ Rotators hydrauliques

- ■ ■ ■ Hydraulische Drehmotoren
- ■ ■ ■ Rotores hidráulicos
- ■ ■ ■ Гидравлические ротаторы

> R3IR

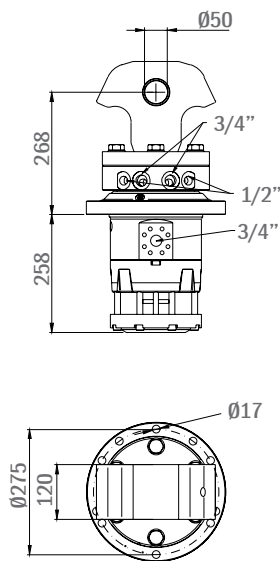

> R3BIR

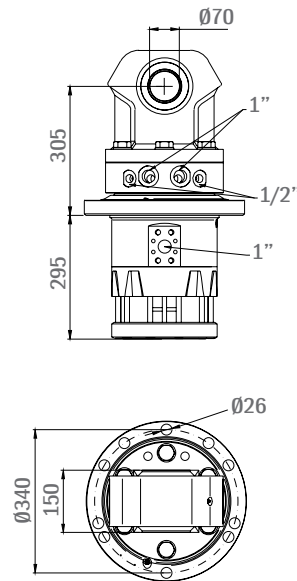

> R3C

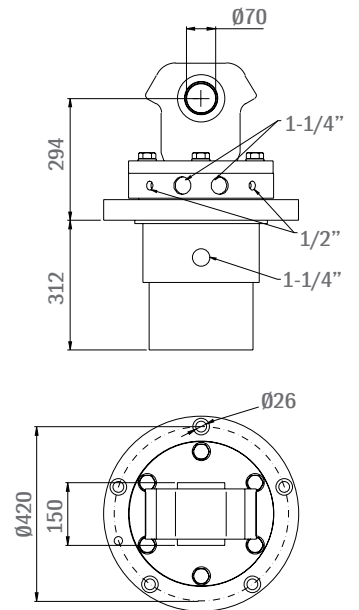

Modello	Portata	Peso	Coppia	Pressione	Portata olio	Pressione
Model	Lifting capacity	Weight	Torque	Pressure	Oil flow	Pressure
Modèle	Portée	Poids	Couple	Pression	Débit d'huile	Pression
Modell	Tragkraft	Gewicht	Drehmoment	Druck	Ölleistung	Druck
	t	kg	kgm	bar	l/min	bar
R3IR	7	125	210	190	25	350
R3BIR	12	205	410	250	35	350
R3C	15	252	240	200	35	300

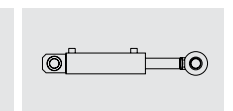
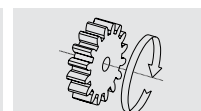
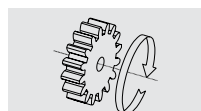

- ■ Rotatori idraulici
- ■ Hydraulic rotators
- ■ Rotators hydrauliques

- ■ ■ ■ Hydraulische Drehmotoren
- ■ ■ ■ Rotores hidráulicos
- ■ ■ ■ Гидравлические ротаторы

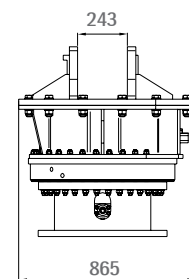
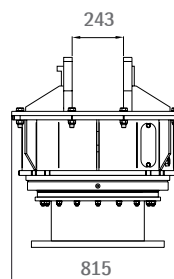
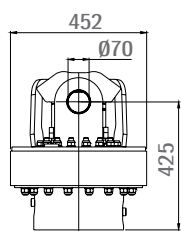
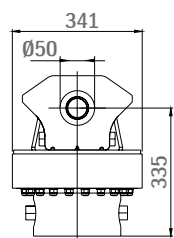
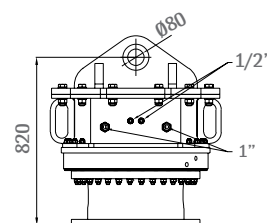
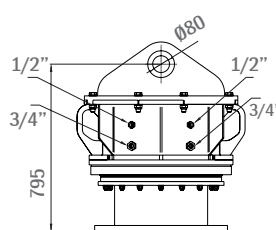
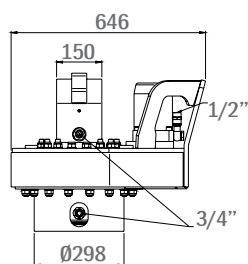
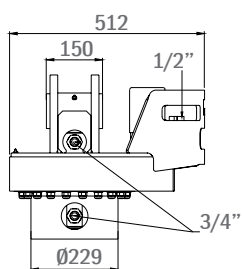

>R1G



>R4G

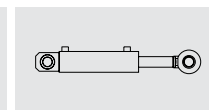
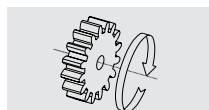
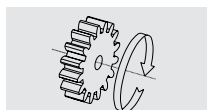

>R45G

>R5G

Modello	Portata	Peso	Coppia	Pressione	Portata olio	Pressione
Model	Lifting capacity	Weight	Torque	Pressure	Oil flow	Pressure
Modèle	Portée	Poids	Couple	Pression	Débit d'huile	Pression
Modell	Tragkraft	Gewicht	Drehmoment	Druck	Ölleistung	Druck
	t	kg	kgm	bar	l/min	bar
R1G	5	100	185	110	35	300
R4G	8	220	380	150	40	300
R45G	12	500	290	170	30	300
R5G	18	720	400	200	35	300



 Giunti idraulici
 Free rotators
 Joints tournants hydrauliques

 Hydraulische Drehdurchführungen
 Juntas hidráulicas
 Гидравлические ротаторы

> R2 IR10

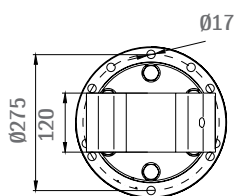
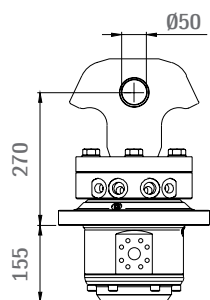

> R2 BIR20

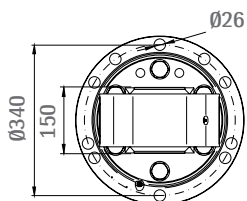
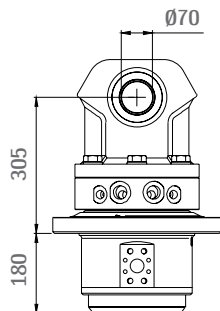



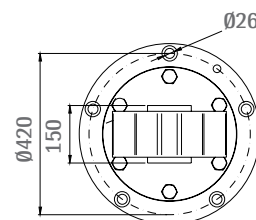
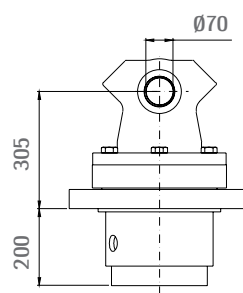

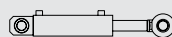

> R2C



Modello	Portata	Peso	Pressione
Model	Lifting capacity	Weight	Pressure
Modèle	Portée	Poids	Pression
Modell	Tragkraft	Gewicht	Druck
	t	kg	bar
R2 IR10	7	130	350
R2 BIR20	12	175	350
R2C	15	224	300



-  Avolgitubo
-  Hose-reel
-  Enrouleur

-  Schlauchwickler
-  Enrollador de tubos
-  Рукавная катушка

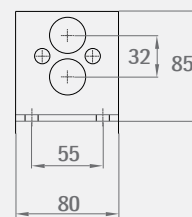
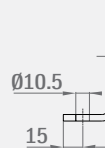
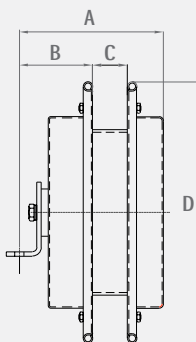
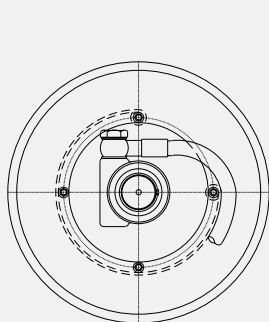

Modello	Corsa	Peso	Pressione	Sezione tubo	Lunghezza tubo	Dimensioni			
Model	Stroke	Weight	Pressure	Hose section	Hose length	Sizes			
Modèle	Course	Poids	Pression	Section du flexible	Longueur du flexible	Dimensions			
Modell	Hub	Gewicht	Druck	Schlauchdurchmesser	Schlauchlänge	Abmessungen			
	m	kg	bar		m	A	B	C	D
RX30	1.9	9	280	3/8"	3	150	70	40	300
RX35	3.9	9.5	280	3/8"	5	150	70	40	350
RX40	6.4	10	280	3/8"	7.5	150	70	40	400
RX45	7.6	29	280	3/8"	9	164	82	40	450
RX52	10.6	31.5	280	3/8"	12	164	82	40	525